



S-Series

Flexible Screw Conveyors

Versatile - Efficient - Rugged



Conveys a broad range of bulk materials.

S-Series Flexible Screw Conveyors transport powders, flakes, granules and pellets. They easily manage hard-to-handle materials that aerate, pack under pressure, agglomerate, generate static or are very light or windswept.

Offers flexible in-plant layouts.

The S-Series conveys vertically up to 35 feet and horizontally up to 80 feet. Smaller diameter models can be bent to avoid obstructions and use minimal floor space.

Engineered and built tougher.

S-Series Conveyors are truly engineered for industrial applications. They use heavier gauge sheet metal, durable seals and thicker, one piece, gaskets in the hopper / drive component areas. A combination of standard Tech3 innovations which provide longer life, higher reliability and lower maintenance costs. Contact us and compare our differences and value!

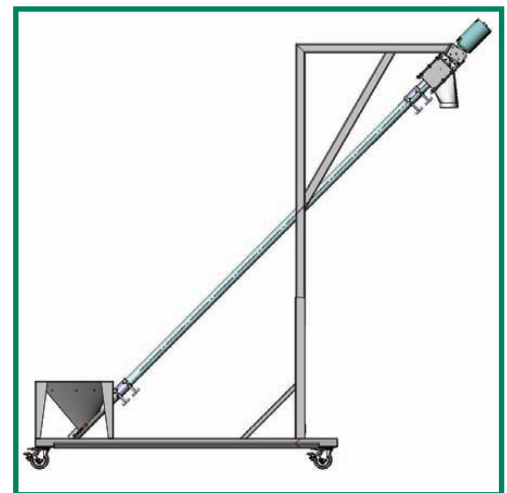

Portable base (fixed or tilting)

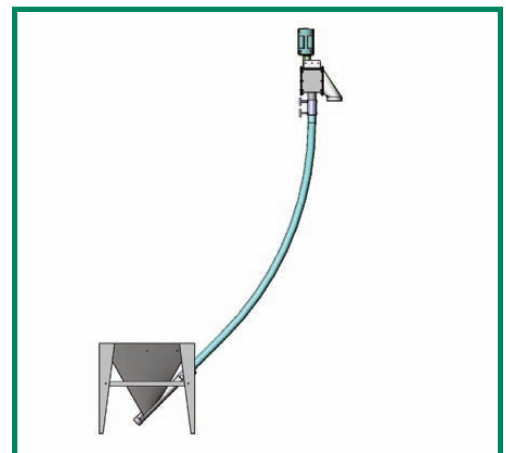

Curved conveyor path



Optional flanged inlet



S-Series Flexible Screw Conveyors

Conveyor Specifications >>

Model	S-30	S-40	S-50	S-60	S-80
Casing (O.D.)	2.96" or 3.125"	4.2" or 4.5"	4.7"	6.625"	8.625"
Bend radius	10'	20'	N/A	N/A	N/A
Max capacity*	50-180 ft ³ /hr	60-300 ft ³ /hr	60-480 ft ³ /hr	120-800 ft ³ /hr	180-1800 ft ³ /hr

* Based on free-flowing granular material. Actual capacity will vary with material characteristics, conveyor pickup angle and auger selection. Consult your Tech3 representative for more information.

Conveyor Auger Options >>

Augers	Standard duty	Heavy duty
Flat auger	X	X
Beveled edge	X	X
Square		X
Round	X	X



Options for ease of use and seamless integration with existing equipment.

Specify quick release T-handle couplings, custom support frames and hoppers (standard or conical). Incorporate vibration / agitation options to enhance product flow. Special engineered boot assemblies and flanged inlets allow connection to bulk bag unloaders, mixers, bag dump stations and other processing equipment. S-Series flexible screw conveyors standard finish is food grade. Optional finishes include industrial (carbon steel) and sanitary (stainless steel). Mild steel, 304 stainless or 316 stainless is used in construction.



T-handle couplings



Snap on end cap



Superior hoppers

Easy to clean between product runs.

To evacuate the conveyor for cleaning, simply remove the boot assembly end cap and reverse jog the auger. Additional cleaning can be accomplished by flushing with air, steam or cleaning solution. The easy-to-clean S-Series system reduces labor costs and assures contamination-free handling of all materials.

S-Series conveyors – Move ahead.

Tech3 Manufacturing Co.
 Phone - (269) 375-4469 or (269) 207-7360
 Fax - (269) 375-4479
 E-mail - jdurlach@tech3mfg.com
 P.O. Box 2026
 Kalamazoo, MI 49003-2026

www.tech3mfg.com

**Guaranteed High Quality
 And Low Cost!**